



[www.huawei.com](http://www.huawei.com)

# Layer 2 Openflow Use Cases

**Authors:** Ruobin Zheng; Wenle Yang; Hesham ElBakoury

**Version:** 1.0

**HUAWEI TECHNOLOGIES CO., LTD.**



# Agenda

- **Review Different Use Cases to Support Using Openflow over L2 Networks**
  - BBF Use Cases.
  - Network Virtualization Use Cases
    - Cablelabs Virtual CCAP.
    - ETSI & BBF Use Case (wholesale & retailers)
  - Hybrid MPLS (H-MPLS) Use Case
- **The need for Layer 2 Openflow**
  - Using L2 Openflow to support Hybrid MPLS
- **Huawei L2 Openflow Demos**
- **Using IEEE 1904.2 for L2 Openflow**
- **L2 Openflow Standardization Plan in ITU.**

1

# Broadband Forum Use Cases

# Use Case in BBF SD-313: Remote Nodes Plug & Play in Access Networks

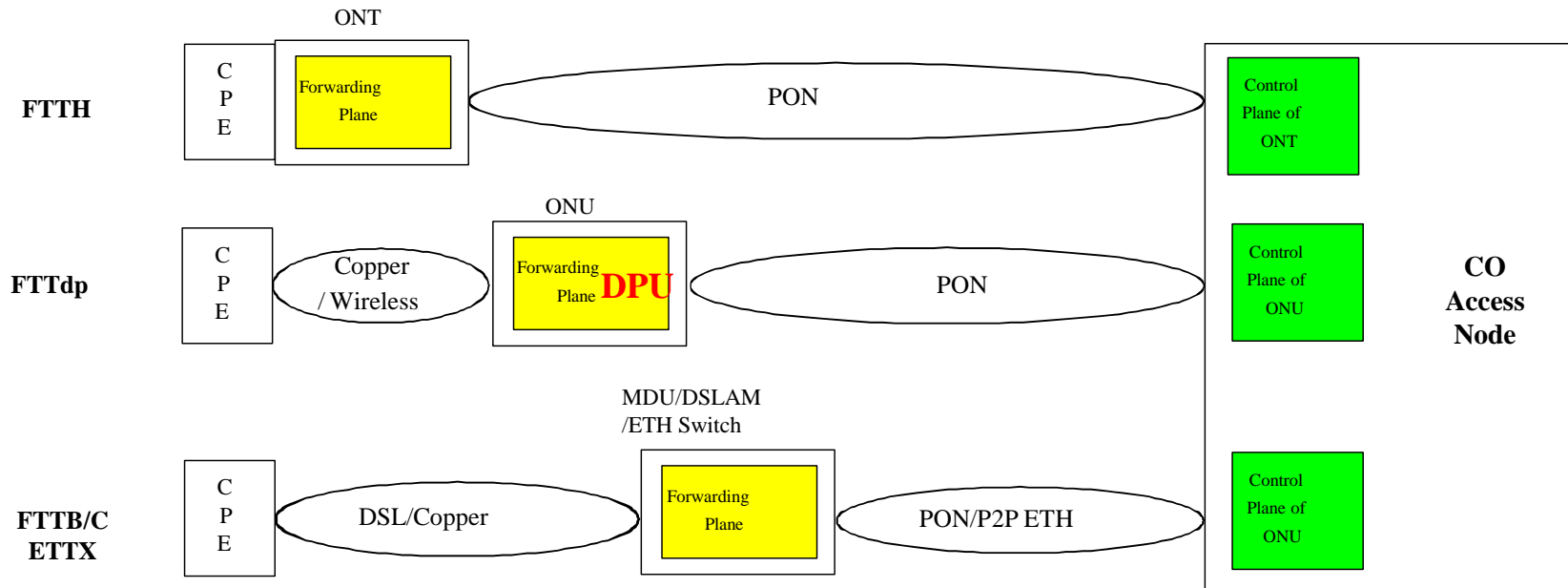

- Control planes of remote nodes are moved to the aggregation OLT, while remote nodes keep forwarding plane. No IP address or configuration is needed on the remote node to make it work.

# C-DOCSIS Architecture

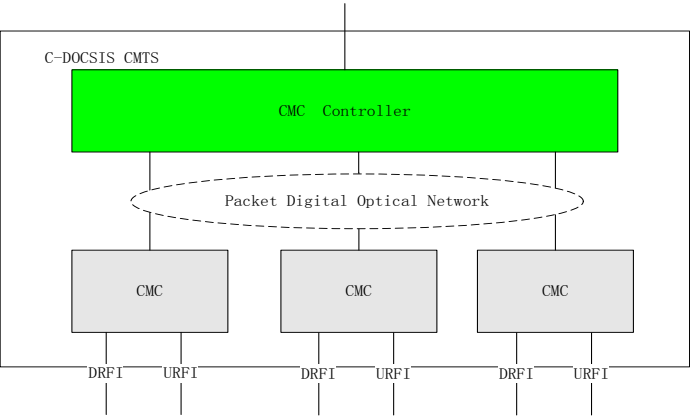
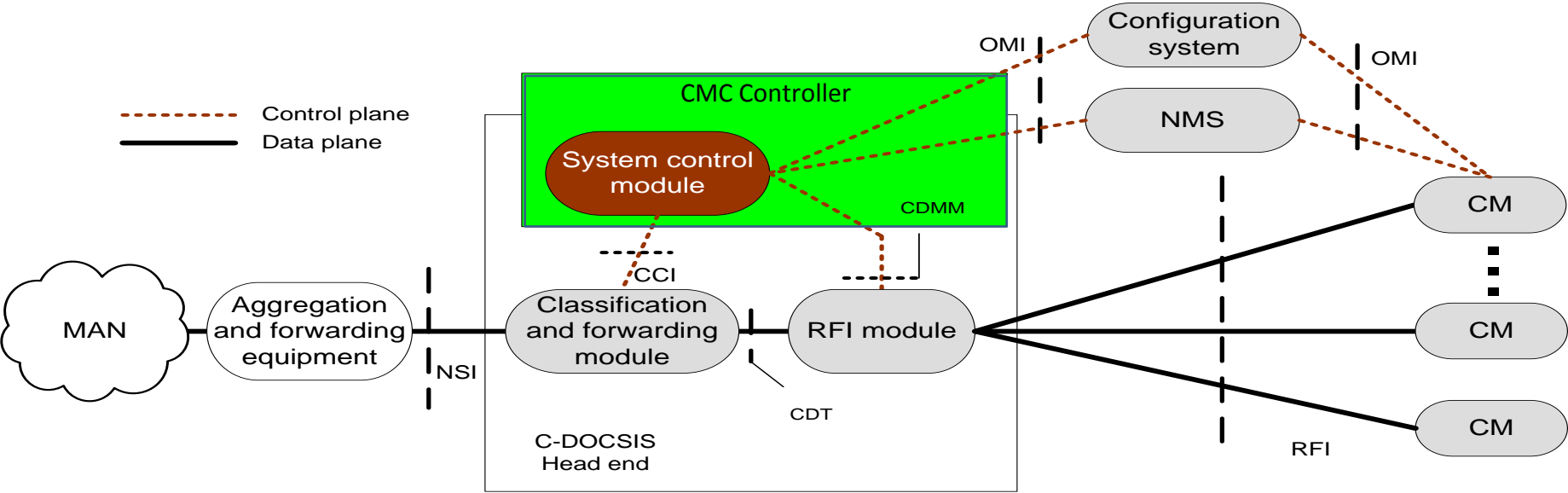

C-DOCSIS Headend consists of CMC Controller and CMC  
 C-DOCSIS Headend can assume the role of traditional CMTS

# Use Case in BBF: Three Architectures Collapse to One single Architecture through Open Programmability

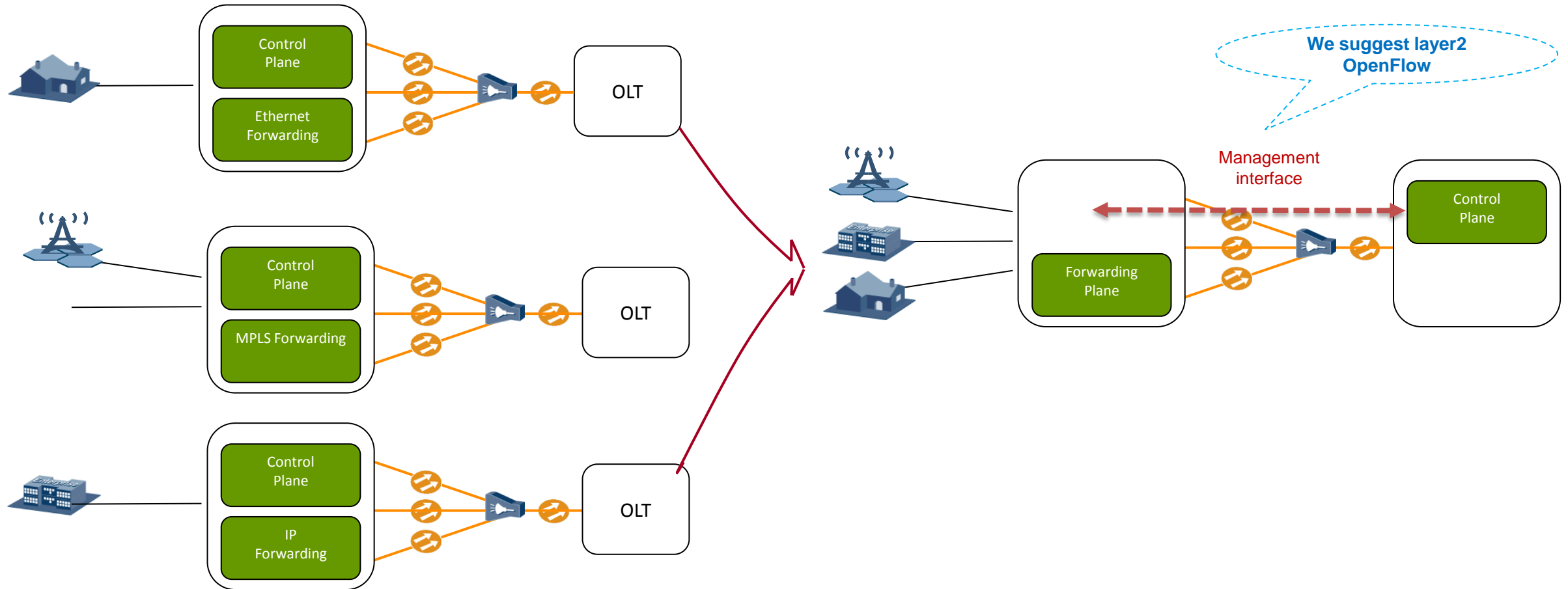

➤ SD 313 “ **The three disparate architectures** described in WT-178 could have been **collapsed into a single architecture** where **access nodes are controlled by SDN**. SDN could enable assignment of labels without the need of provisioning or Downstream on-Demand LDP. It can even stitch and enable MPLS access, IP routing behavior, or simply Ethernet forwarding according to the desire of the service provider.”

2

## Network Virtualization Use Cases

# Network Virtualization

- **The following Network Virtualization Use Cases are presented:**
  - Virtual Access Node
  - Virtual Access Network
    - Network nodes physical or logical can be combined or segregated to form different virtual access networks
  - Network as a Service (**NaaS**)
    - NaaS allows a service provider to use a virtualized network infrastructure to provide network services to consumers..
    - It is the responsibility of NaaS provider to maintain and manage the network resources which decreases the workload from the consumer.
    - Moreover NaaS offers network as a utility.
- **Network Virtualization Attributes**
  - **Abstraction:** Details of network hardware are hidden.
  - **Resource Sharing:** Network elements can be partitioned and utilized by multiple virtual networks.
  - **Isolation:** loose or strict isolation between virtual networks must be provided.
- **Opensource: OpenDaylight VTN and OpenNaaS.**



# Cablelabs V-CCAP Architecture Based on C-DOCSIS

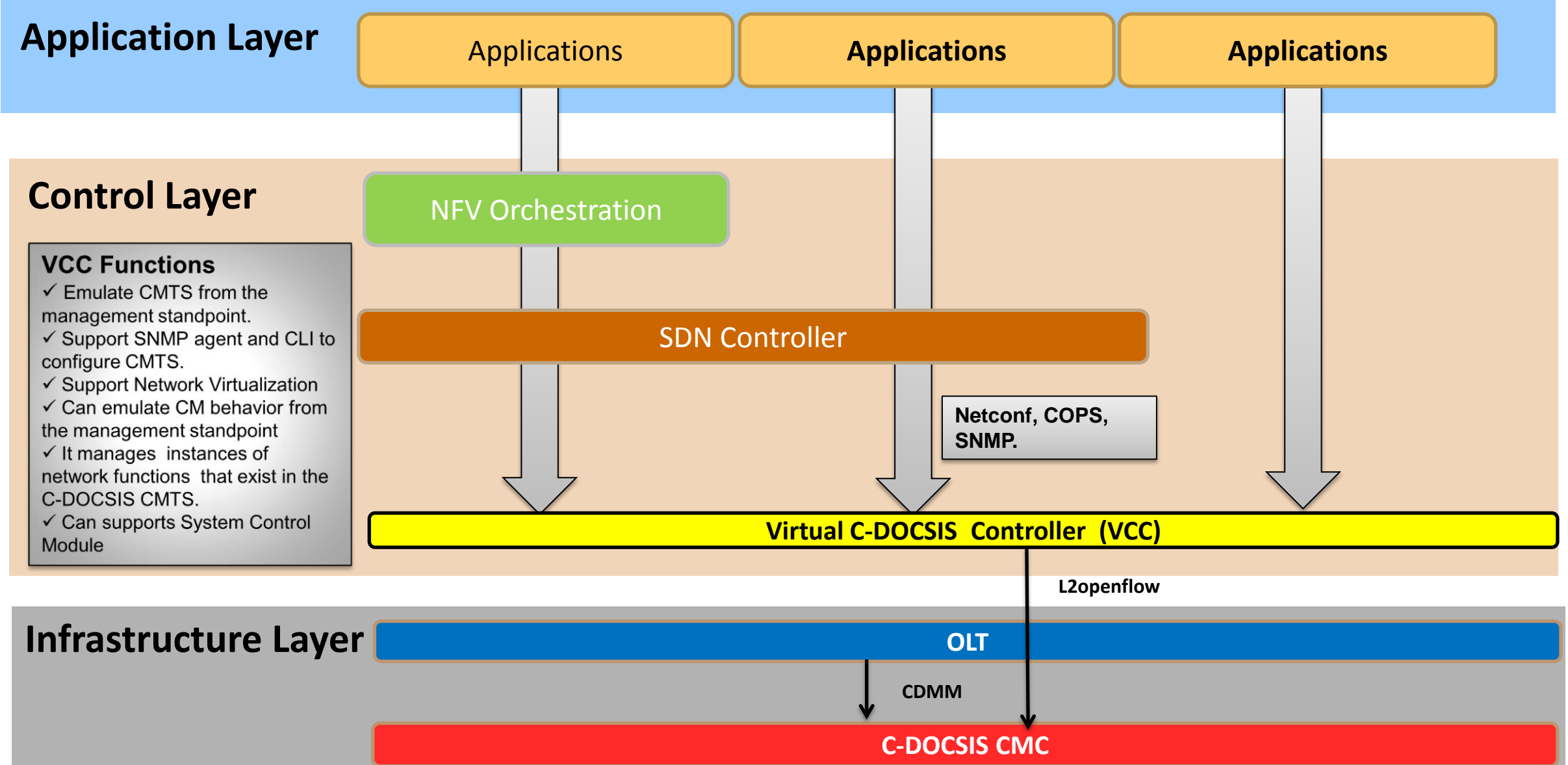

# Use Case in ETSI NFV & BBF SD-313: Access Network Virtualization

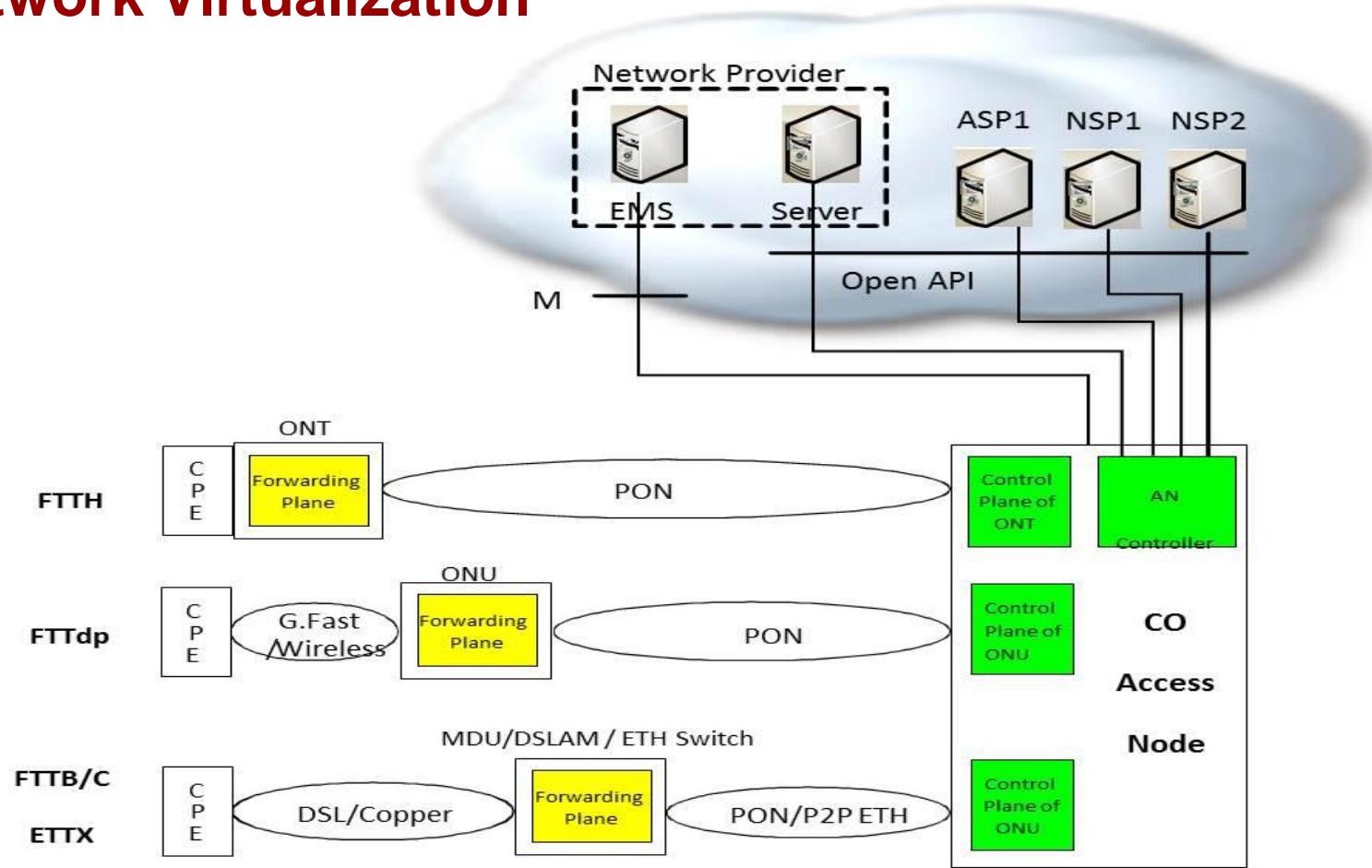

➤ ETSI Use Case #9 BBF Use case: **Access Network Open Interface for Wholesale or Enhanced Service.**

➤ CO Access Node has an AN controller implementing Access Network abstraction and slicing. The AN controller also provides an open control/management interface, e.g. open API that can be used directly by other Service Provider/Network retailer.

# Example of Type 1 Virtual Access Node

Physical deployment

OSS/NMS logic network view

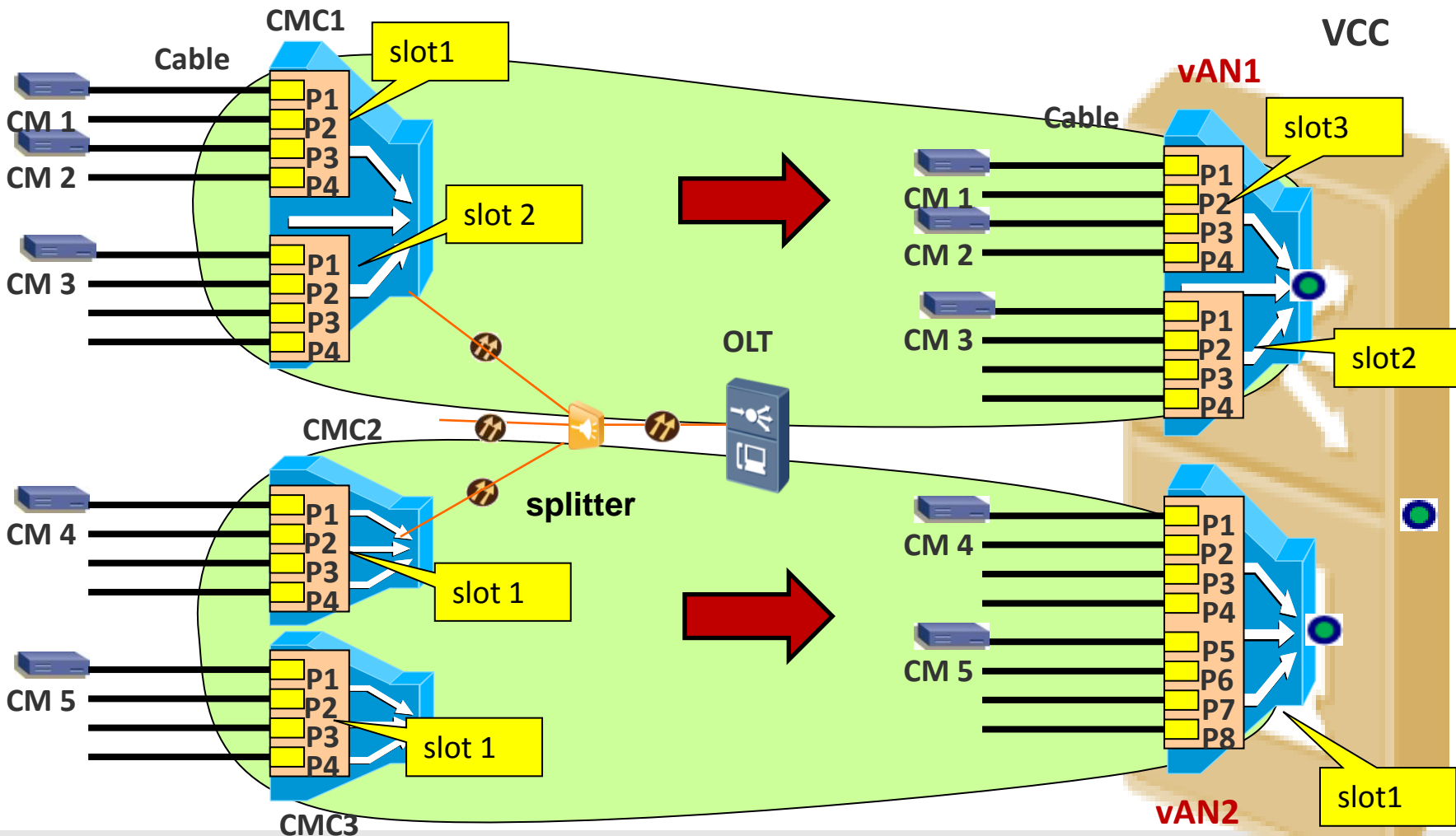

This Table is maintained by vAN instance

Physical Line ID	Virtual Line ID
CMC1/slot2/port1	vAN1/ slot2/port1
.....	.....
CMC1/slot2/port4	vAN1/ slot2/port4
CMC1/slot1/port1	vAN1/ slot3/port1
.....	.....
CMC1/slot1/port4	vAN1/ slot3/port4

Physical Line ID	Virtual Line ID
CMC3/slot1/port1	vAN2/ slot1/port1
.....	.....
CMC3/slot1/port4	vAN2/ slot1/port4
CMC2/slot1/port1	vAN2/ slot1/port5
.....	.....
CMC2/slot1/port4	vAN2/ slot1/port8

# Another example of Type 1 virtual AN

Physical deployment

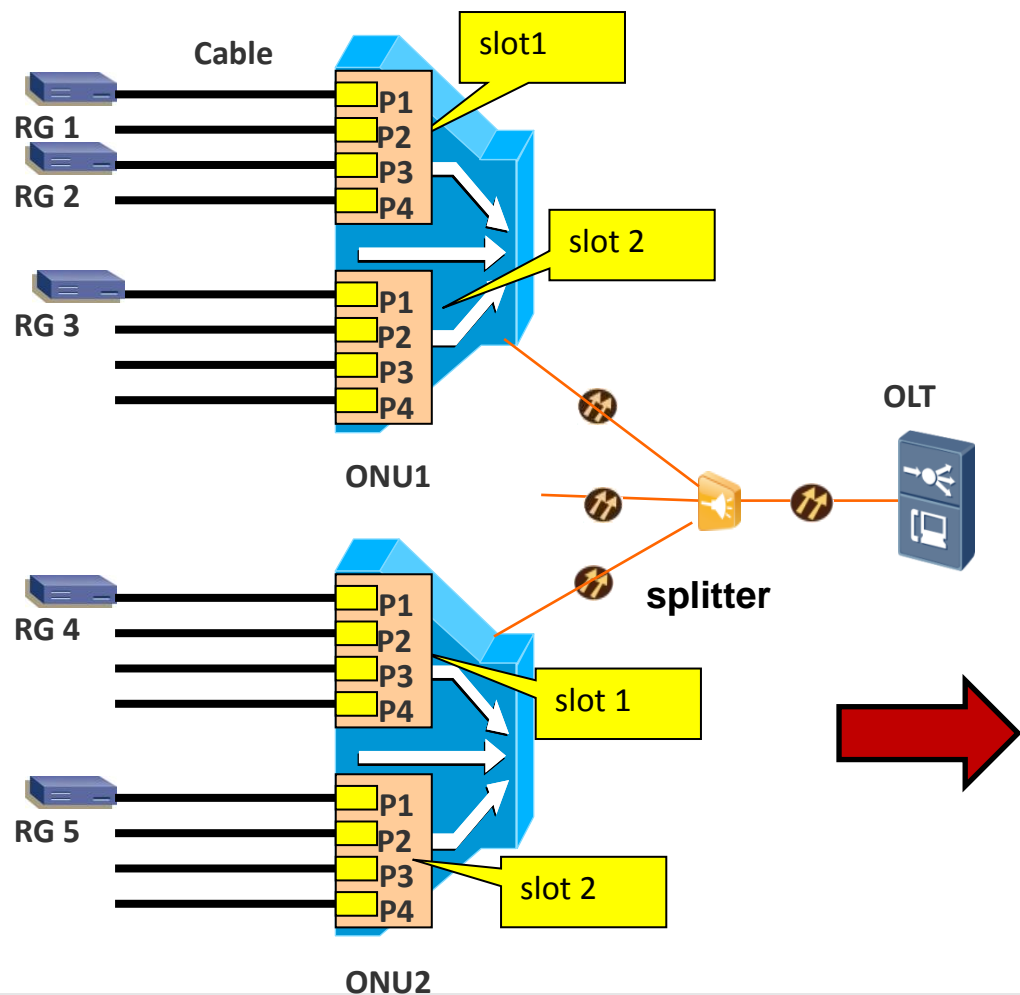

OSS/NMS logic network view

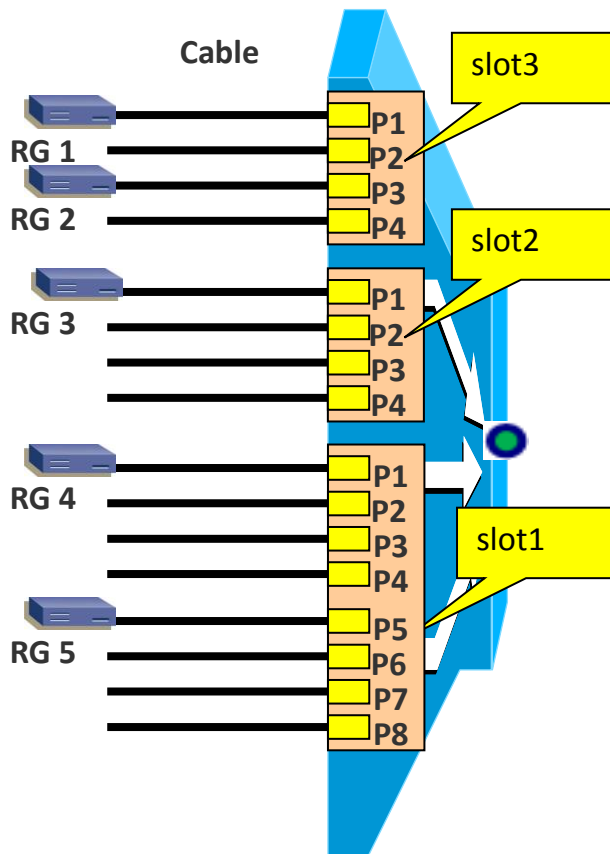

Physical Line ID	Virtual Line ID
ONU2/slot1/port1	AN/ slot1/port1
.....	.....
ONU2/slot1/port4	AN/ slot1/port4
ONU2/slot2/port1	AN/ slot1/port5
.....	.....
ONU2/slot2/port4	AN/ slot1/port8
ONU1/slot2/port1	AN/ slot2/port1
.....	.....
ONU1/slot2/port4	AN/ slot2/port4
ONU1/slot1/port1	AN/ slot3/port1
.....	.....
ONU1/slot1/port4	AN/ slot3/port4

# MSO Use of Type1 Virtual AN

Physical  
Remote AN1

1. When a remote AN is up, a vAN will be automatically generated.

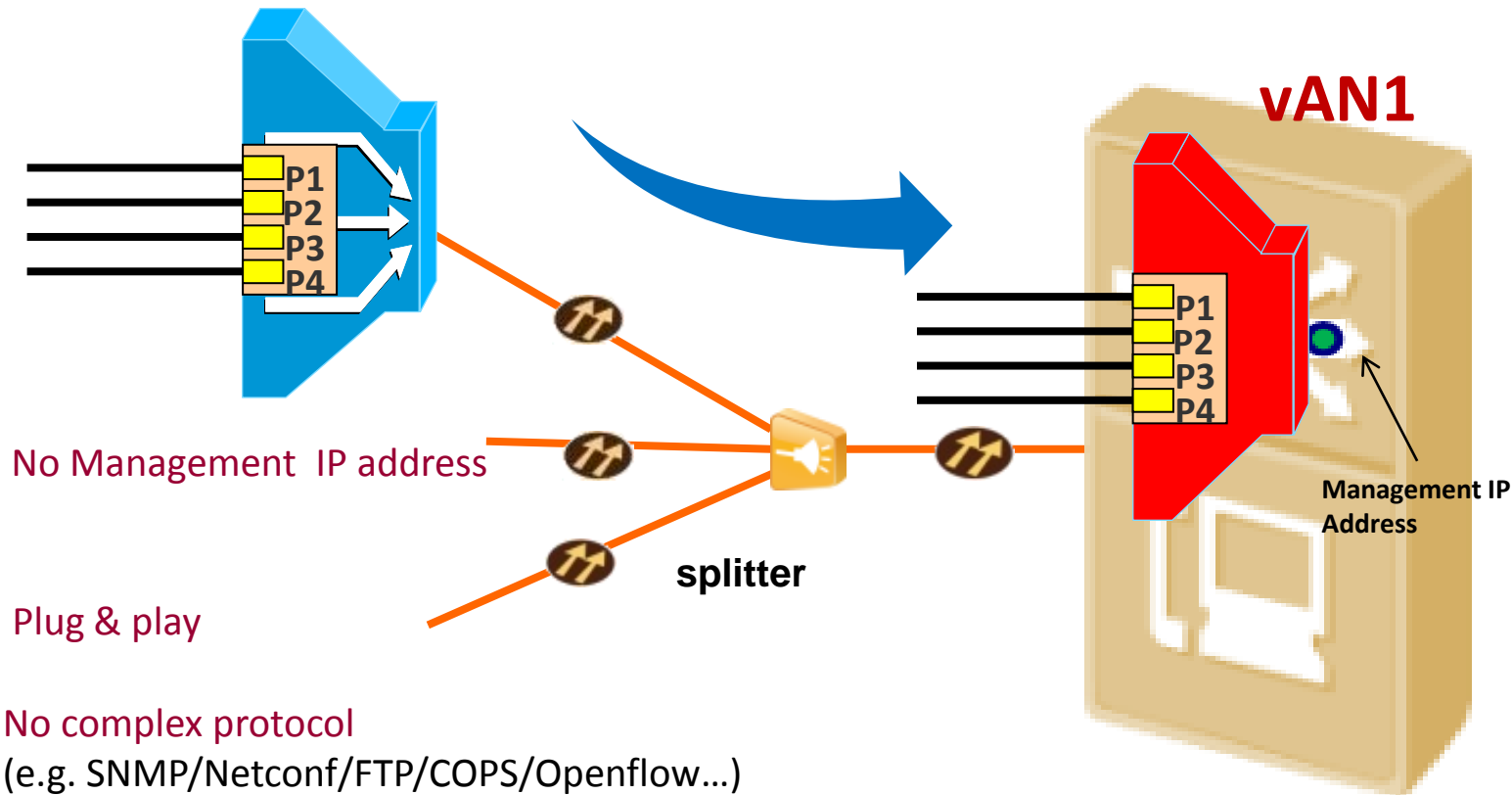

2. vAN will automatically get a management IP address for vAN.

3. vAN initiates auto-configuration and provisioning to support remote AN Plug&play.

4. vAN does protocol conversion between layer3 (e.g. SNMP/Netconf/FTP/ COPS/Openflow...) and layer2 (e.g. OMCI/ETH OAM)

# Example of Type 2 Virtual Access Node

Physical deployment

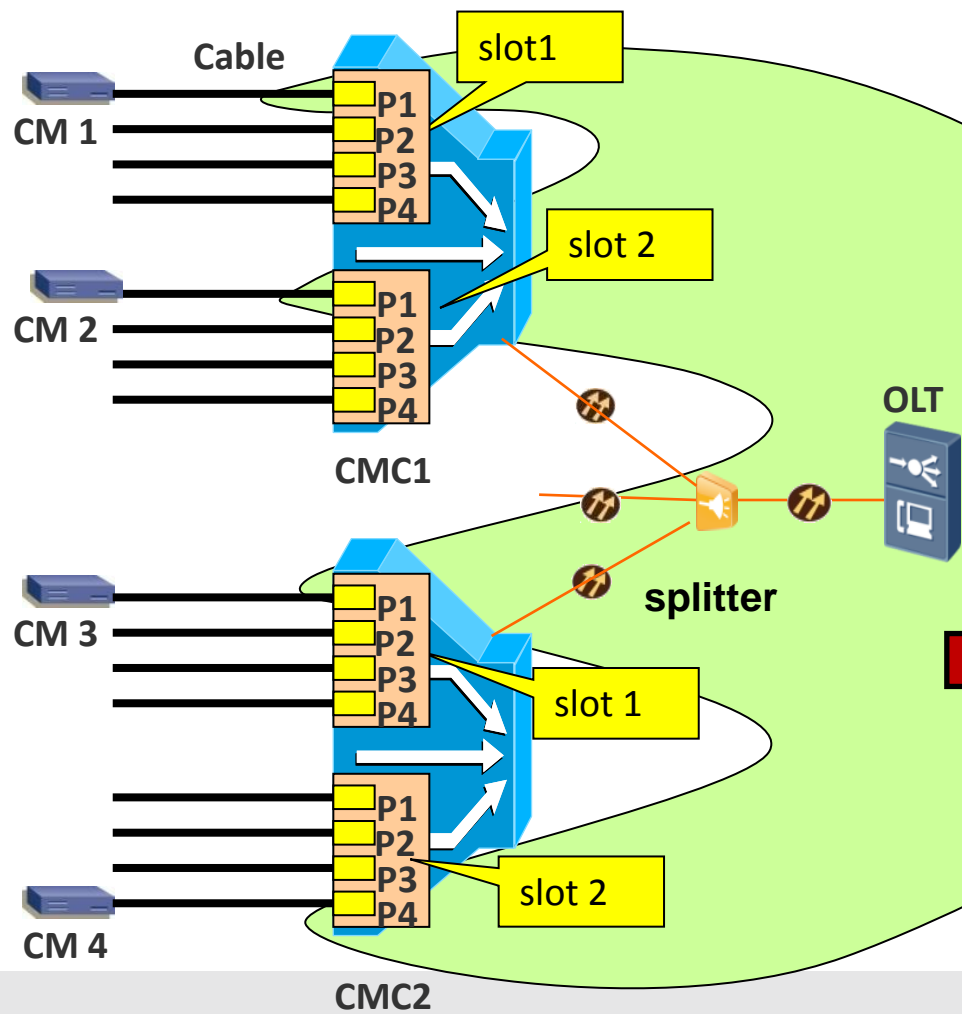

OSS/NMS logic network view

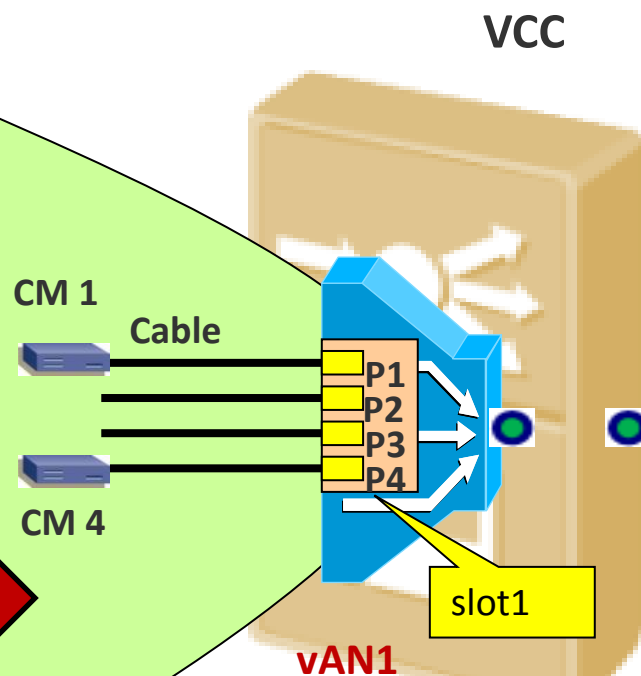

This Table is maintained by vAN instance

Physical Line ID	Virtual Line ID
CMC1/slot1/port1/CM ID	vAN1/ slot1/port1/CM ID
.....	
CMC1/slot1/port4/CM ID	
CMC1/slot2/port1/CM ID	vAN1/ slot1/port2/CM ID
.....	
CMC1/slot2/port4/CM ID	
CMC2/slot2/port1/CM ID	vAN1/ slot1/port3/CM ID
.....	
CMC2/slot2/port4/CM ID	
CMC2/slot1/port1/CM ID	
.....	
CMC2/slot1/port4/CM ID	vAN1/ slot1/port4/CM ID

# Virtual Access Network Wholesale for both Type1 and Type 2 Virtual Access Node

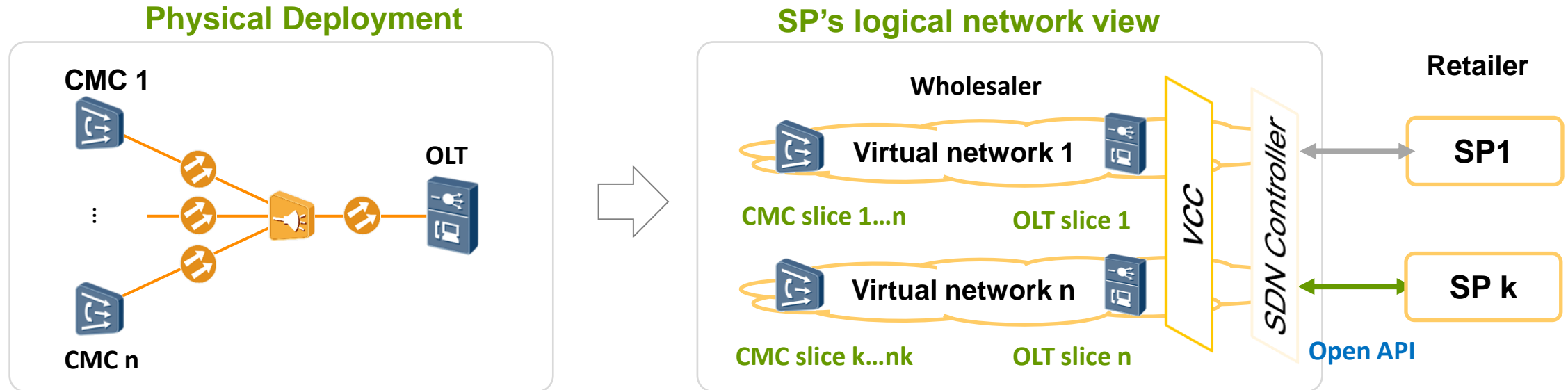

- Slice one physical network into several virtual access network. Each virtual network can be wholesaled to different retailers.
- Virtual networks are totally separated on both data plane and control plane.

# The Concept of Virtual Access Node

- **A virtual AN is a virtual entity that represent Remote ANs or part thereof.**
- **OSS/NMS only can see virtual AN rather than Remote AN.**
- **Virtual AN Instance supports the following functions:**
  - Support Remote AN plug & play
  - Keep Remote AN as simple as possible;
  - Function as a proxy between Remote AN and OSS/NMS/...
  - Provide protocol conversion between layer 3 (e.g. SNMP/Netconf/FTP/PCMM/Openflow...) and layer 2 (e.g OMCI/ETH, OAM)



# Benefits of Virtual Access Node

- **Simplified Remote nodes**
  - Plug-&-Play
  - No Management IP address
  - No complex protocols
- **Supports smooth migration from integrated to distributed CCAP/CMTS for Cable access networks.**
  - Abstracts the common model of DOCSIS management and service provisioning, isolating the difference of architecture.
  - No changes to OSS.
- **One Touch service provisioning**
  - Hide the details of the hardware infrastructure.

# Benefits of Virtual Access Network Wholesale for both Type1 and Type2 Virtual AN

- **Benefits of Virtual Networks**
  - Multi-tenant access network wholesale with open API
  - Infrastructure sharing reduce TCO.
  - Save OPEX because retailers provisioning new services is implified.
  - Ease of implementation – Use the underlying operator (e.g. MSo) physical network.
  - Virtual Network can scale to include geographically dispersed locations.

3

## Hybrid MPLS (H-MPLS) Use Case

# End to End MPLS

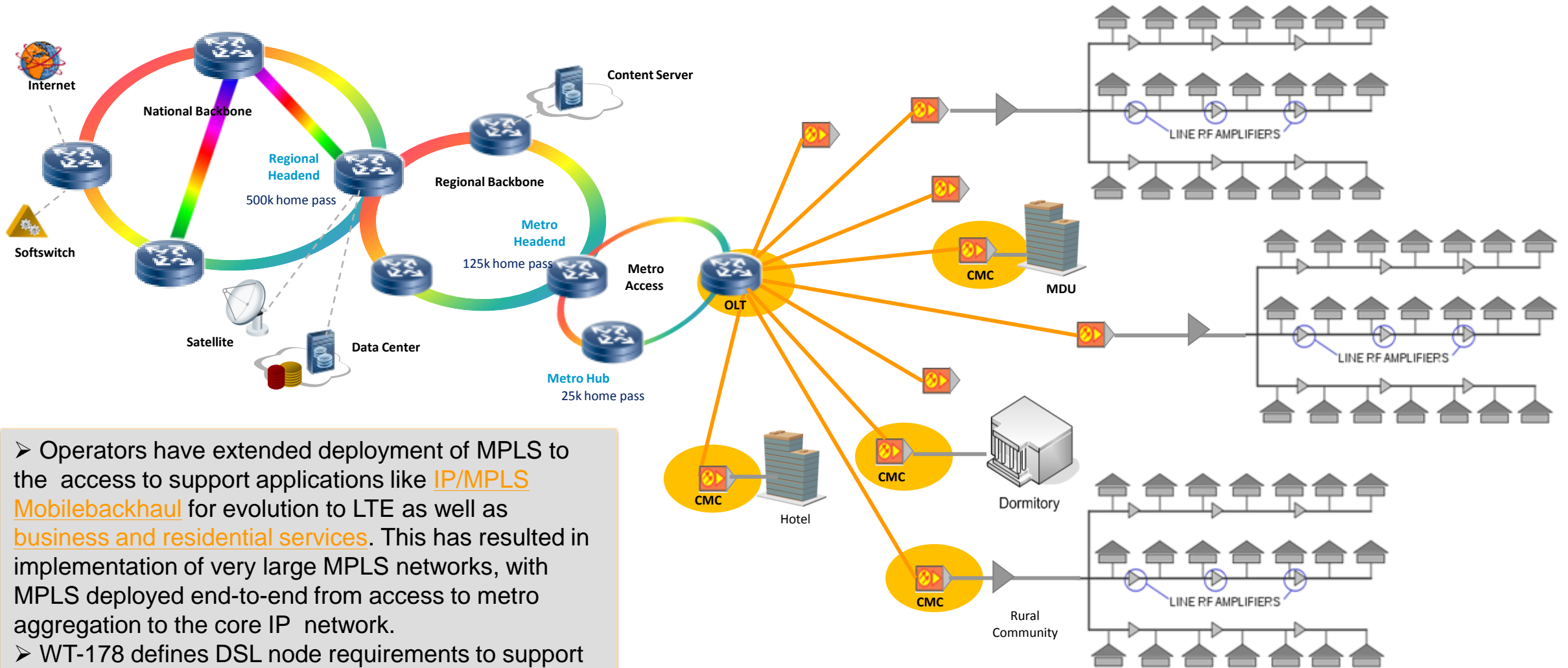

- Operators have extended deployment of MPLS to the access to support applications like [IP/MPLS Mobilebackhaul](#) for evolution to LTE as well as [business and residential services](#). This has resulted in implementation of very large MPLS networks, with MPLS deployed end-to-end from access to metro aggregation to the core IP network.
- WT-178 defines DSL node requirements to support the extension of IP/MPLS to the access network

# Advantages of Extending MPLS to Access (End-to-end MPLS Solution)

- **Consistent Service Definition**
  - Services are transported across different network segments and architecture with common QoS and IP/MPLS OAM and protection capabilities.
- **Transport Layer Independence**
  - MPLS can ride over virtually any transport technology in access, metro and core networks.
- **Scalability**
  - MPLS label space is much larger than VLAN space (4K VLAN IDs). This allows the service provider to support much larger number of service instances.
- **OPEX Reduction**
  - Using one (MPLS) technology end-2-end simplifies service provisioning and reduces OPEX.

# Why Lightweight MPLS in the Access Network

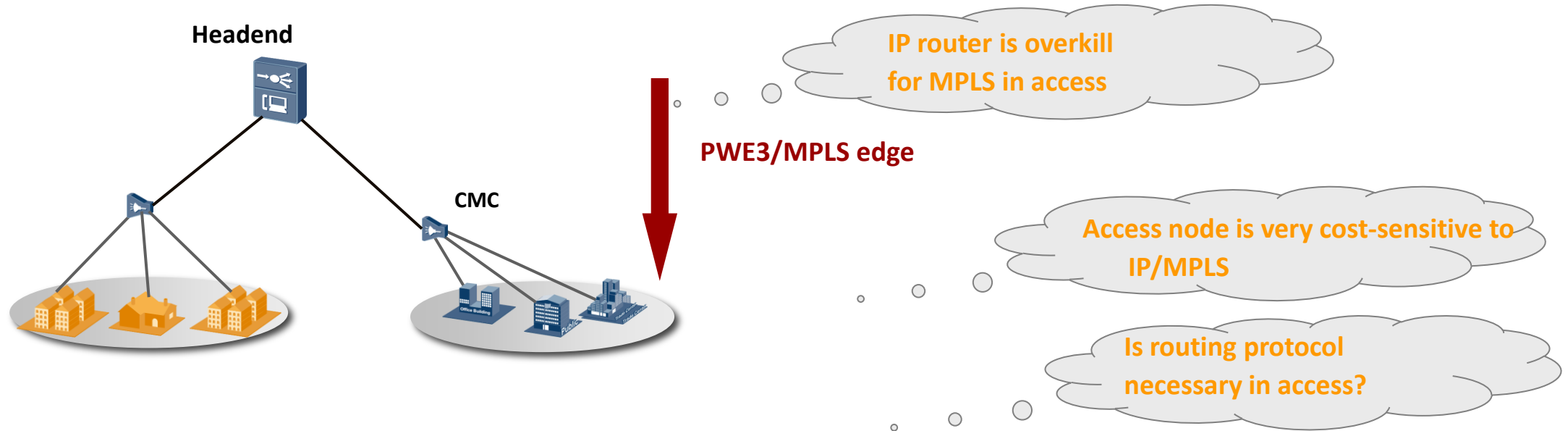

- **Challenges for native MPLS**

- Requiring IP routing and routers everywhere
- IP routing and routing protocol challenge the scalability and complexity of the access network and hinder MPLS from going further into the access network

- **Saving OPEX and Improving performance with lightweight MPLS**

- Enabling the routing-free access network while still using PWE3 to support the required services.
- Simplifying the protocol stack in order to keep access node simple and cost effective

# H-MPLS – A Lightweight SDN-based MPLS Solution for Access Network

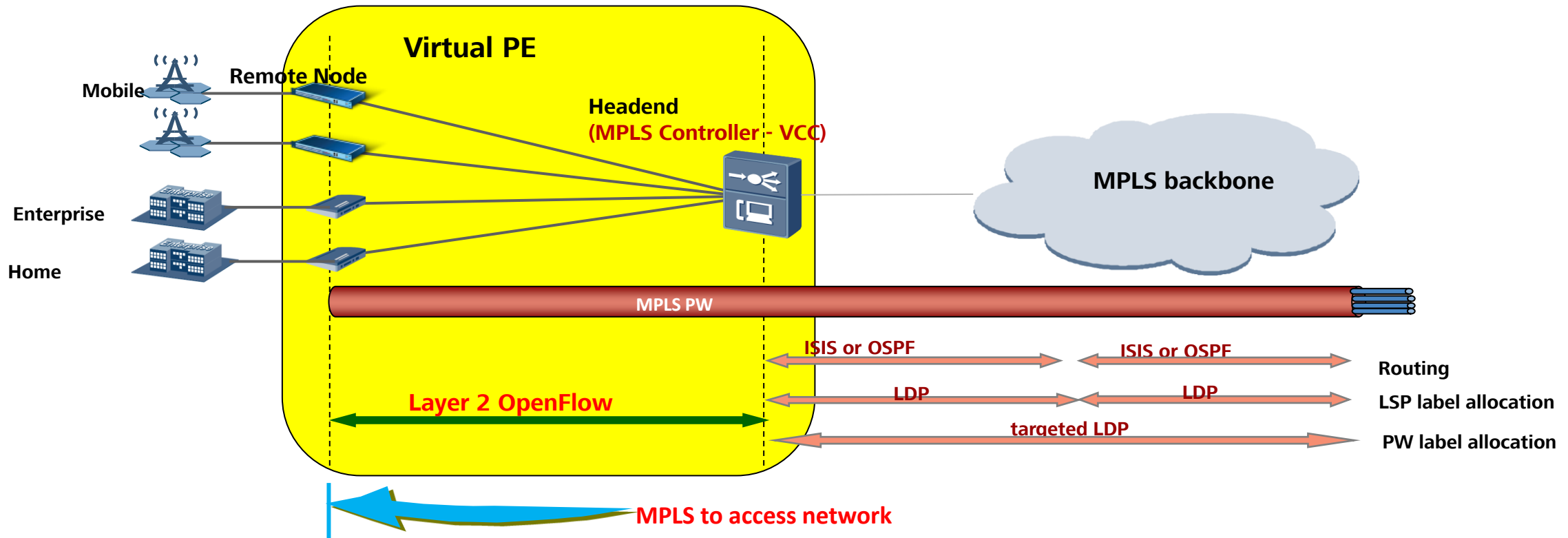

- IP/MPLS control plane of remote nodes (e.g. CMC) is relocated and centralized to a MPLS controller which can be located in the Headend.
- The whole access subnet is virtualized to one node, and shows as one single virtualized PE to the MPLS peer.
- Simplify MPLS control plane in the access network which uses layer 2 OpenFlow for label distribution and service flow mapping.
- Using Layer 2 Openflow for MPLS alleviates the need for full IP/MPLS stack in access nodes, which keeps access segment simple and cost-effective.
- RFC 6456 (Multi-Segment Pseudowires in Passive Optical Network) describes using GPON OMCI to configure labels in GPON (The required OCMI changes have been published).

4

## Using L2 Openflow



# The Need for Layer 2 OpenFlow

- There are two requirements due to the introduction of SDN into access network :
  - Control plane of access node move to the controller, and no IP address on the remote node.
  - Access node should be programmable.
- Openflow (defined by ONF) is the most popular protocol for SDN.
  - Openflow identifies network traffic based on pre-defined match rules that can be statically or dynamically programmed by the SDN control software.
- Layer2 OpenFlow allows Openflow to run over layer2 transport for access network. By doing this:
  - Access node is managed by controller through layer2 Openflow without the need of TCP/IP protocol.
  - Enable a programmable access network.
    - Access node can be programmed to support different services without software/hardware upgrade, accelerating service innovation.

# Using Layer 2 OpenFlow to Control CMC MPLS Operation

- **Layer2 OpenFlow is used by MPLS controller to configure the MPLS forwarding tables on remote nodes.**
- **One example of the MPLS forwarding table for remote node is:**
  - For upstream, match: VLAN = 100  
action: POP VLAN 100, PUSH MPLS label 600
  - For downstream, match: MPLS label 700  
action: POP MPLS label 700, PUSH VLAN 100
- **The above Controller-to-Switch Messages follow OpenFlow specification v1.3.**
- **Layer 2 openflow can use the Ethernet layer 2 management channel being defined by IEEE 1904.2**
  - IEEE 1904.2 Management Channel Transport different management protocols such as TR-69, EOAM, SNMP, ... etc
  - The channel is used to allow a management master to manage devices between CPEs and the management master at any level of the hierarchy.

# L2openflow Prototype

- Huawei has developed a prototype based on layer2 Openflow.
  - In the prototype, control plane of remote nodes are separated and centralized to a controller in OLT. The controller manages remote nodes through layer2 Openflow, and therefore remote nodes do not have to support IP protocol and can be plug-&-play.
- Huawei has already shown the demo at:
  - Mobile World Congress, Barcelona, 2013
  - Broadband World Forum, 2013 (BBWF)
  - SDN Congress, 2013
  - Broadband Forum, 2013
  - Open Networking Summit, 2014
- **A new prototype for cable access also based on layer2 Openflow will be demoed at SCTE, 2014 this September.**



# Huawei L2openflow Demos

Demo at BBWF,2013

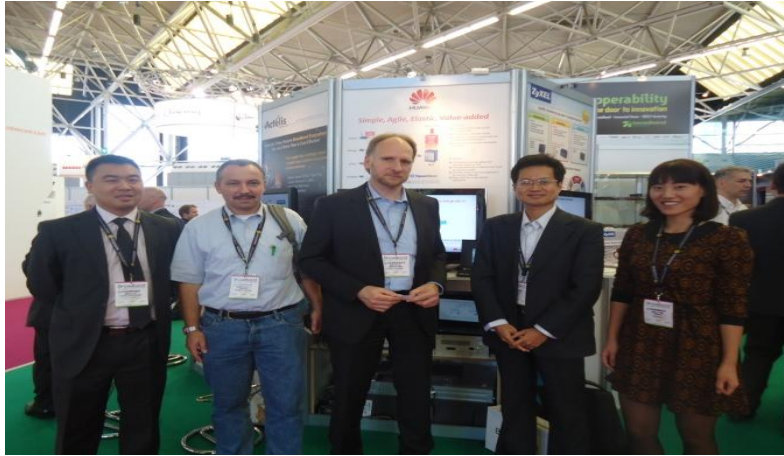

Demo at MWC 2013

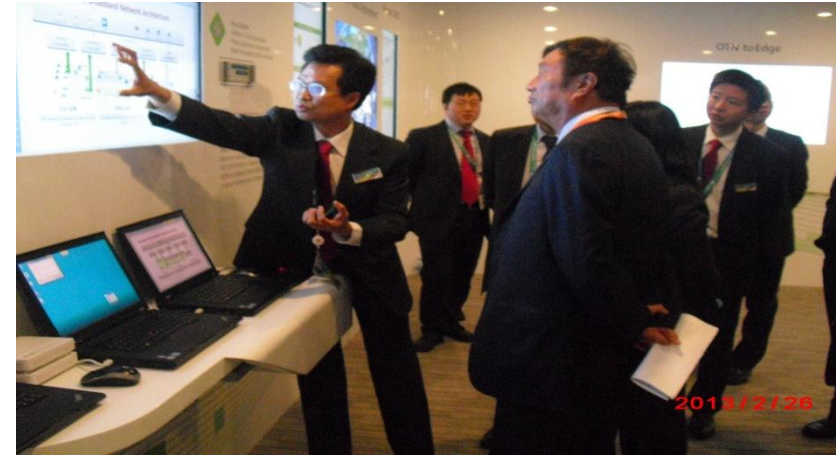

Demo at BBF, 2013



Demo at ONS, 2014



5

Using IEEE 1904.2 UMT for L2 Openflow

# Openflow Standard Evolution (1)

- Main changes between different versions:

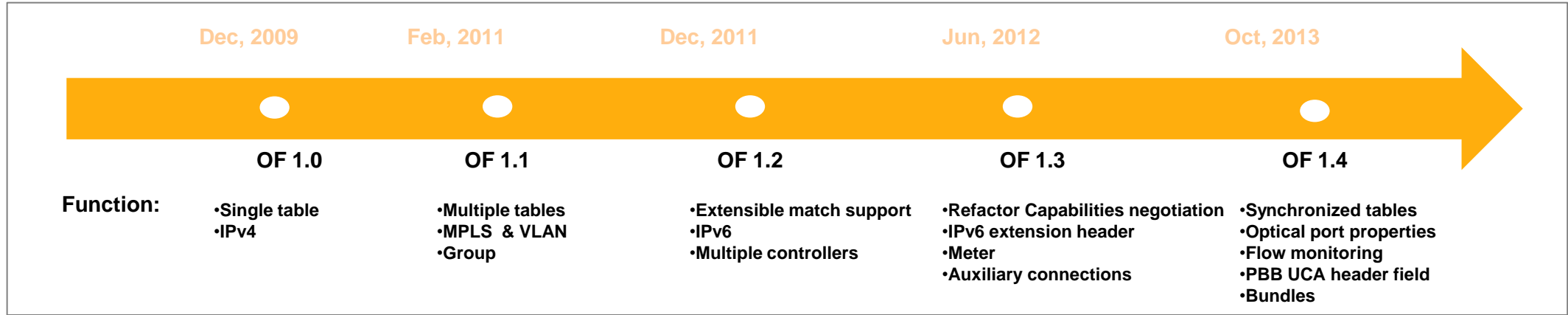

- More instructions and actions are added or modified in different versions according to the function changes.
- Match fields

Version	Match Fields	Main changes
OF 1.0	12 fields	Ethernet, TCP/IPv4
OF 1.1	15 fields	MPLS, inter-table metadata
OF 1.2	36 fields	ARP, ICMP, IPv6
OF 1.3	40 fields	PBB, tunnel-ID, IPv6 extension header.
OF 1.4	41 fields	PBB UCA header

## Openflow Standard Evolution (2)

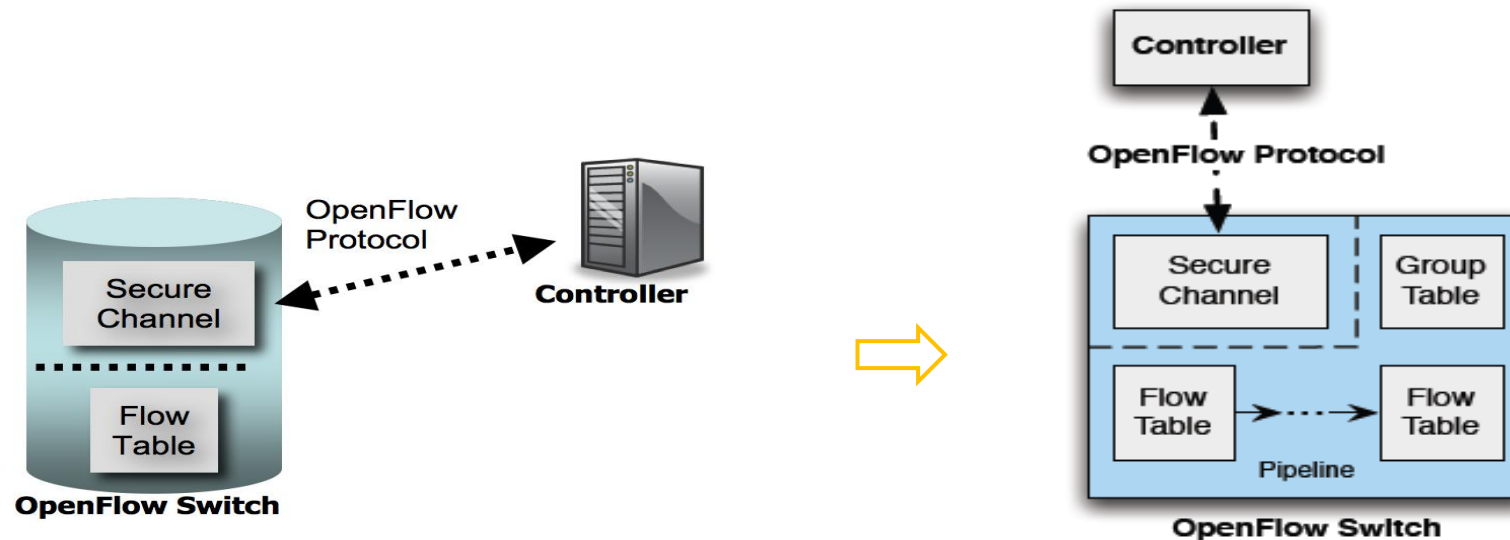

- The figure above describes the changes in Openflow architecture.
- OpenFlow 2.0 now is under discussion and will become a new working group. It will allow OpenFlow to continue evolving along the protocol-specific path and meanwhile enables a protocol-independent branch to be developed in parallel.
  - New data path programming model is going to be defined.

# Using IEEE 1904.2 UMT to provide the L2 Transport for Layer 2 Openflow

- From the previous slide we can see that the Openflow specification has grown increasingly more complicated over the past five years, while more features are still being defined in new versions.
  - Openflow 2.0 will propose new programming models which incurs significant changes on openflow spec.
- Based on this, we suggest using IEEE1904.2 as a transport channel for Openflow instead of developing another OpenFlow-like protocol using eOAM
  - IEEE1904.2 UMT does not need to change to keep pace with Openflow.
  - IEEE 1904.2 provides a universal management channel compatible with Ethernet; it would allow network operators to manage a variety of devices in access network or in subscriber premises in a uniform and consistent way.



# Thank you

[www.huawei.com](http://www.huawei.com)

**Copyright©2011 Huawei Technologies Co., Ltd. All Rights Reserved.**

**The information in this document may contain predictive statements including, without limitation, statements regarding the future financial and operating results, future product portfolio, new technology, etc. There are a number of factors that could cause actual results and developments to differ materially from those expressed or implied in the predictive statements. Therefore, such information is provided for reference purpose only and constitutes neither an offer nor an acceptance. Huawei may change the information at any time without notice.**

# Virtual Network Roles & Players

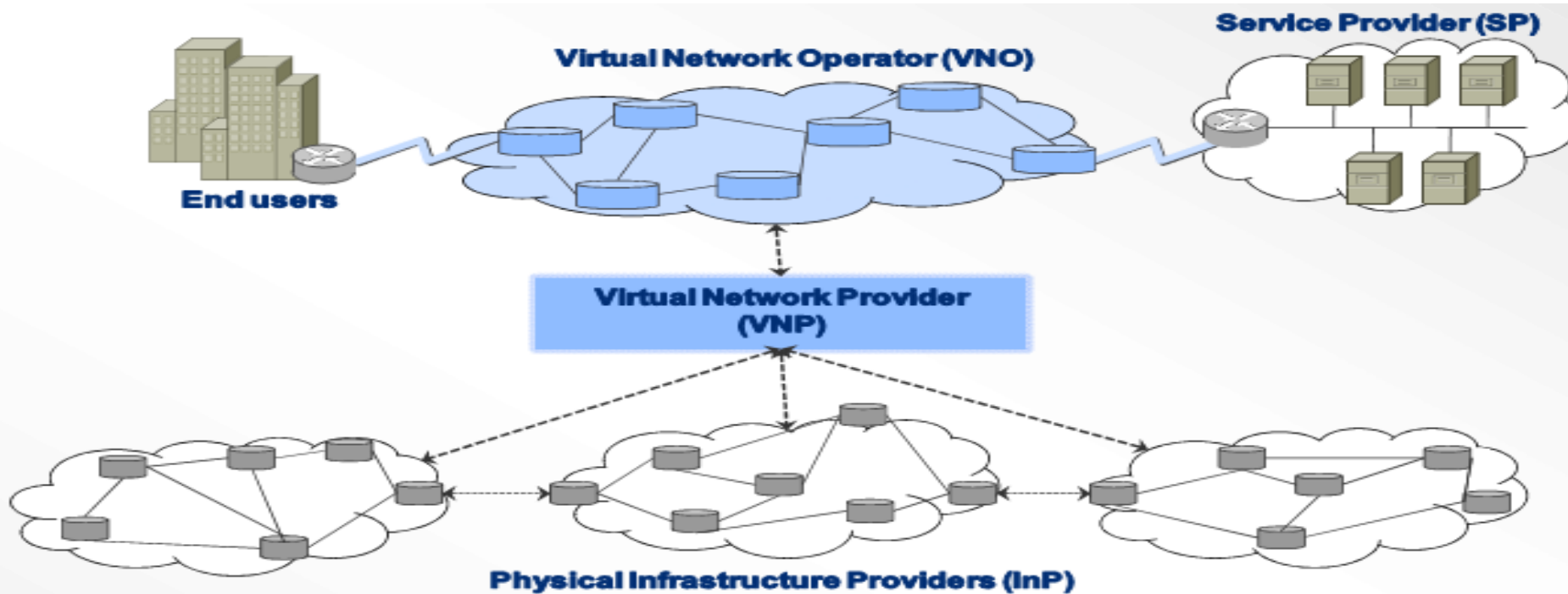

## Possible Deployment Scenarios

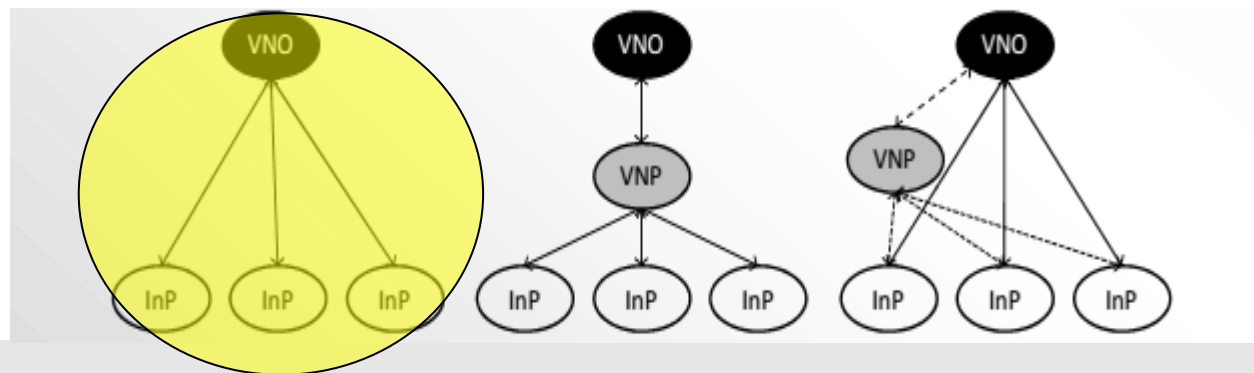

# What is OpenNaaS ?

- An **Open Source Framework** for:
  1. **Virtualizing/Abstracting** network resources
  2. **Managing** (physical and virtual) **networks**
  3. Deploying **dynamic** network **infrastructures**
  4. Supporting **heterogeneous** network devices
  5. Implementing **multi-tenancy** through slicing
  6. **Offering** the Network as a Service (**NaaS**)

# OpenNaaS Value (I)

- Robust and extensible open source framework (<http://www.opennaas.org>)
- Network as a Service (NaaS) model for OAMP management of network infrastructures
- Allows building different types of network service
  - Examples:
    - Virtual infrastructure services
    - Virtual CPE
    - Dynamic provisioning (BoD)
    - Holistic integrated approach for network management
- Recursive delegation of access right over managed resources

# OpenNaaS Value (II)

- **Lightweight Abstracted operational model (HAL)**
  - ✓ Decoupled from actual vendor-specific details
  - ✓ Flexible enough to accommodate different designs and orientations
  - ✓ Fixed enough so common tools can be build and reused across plugins

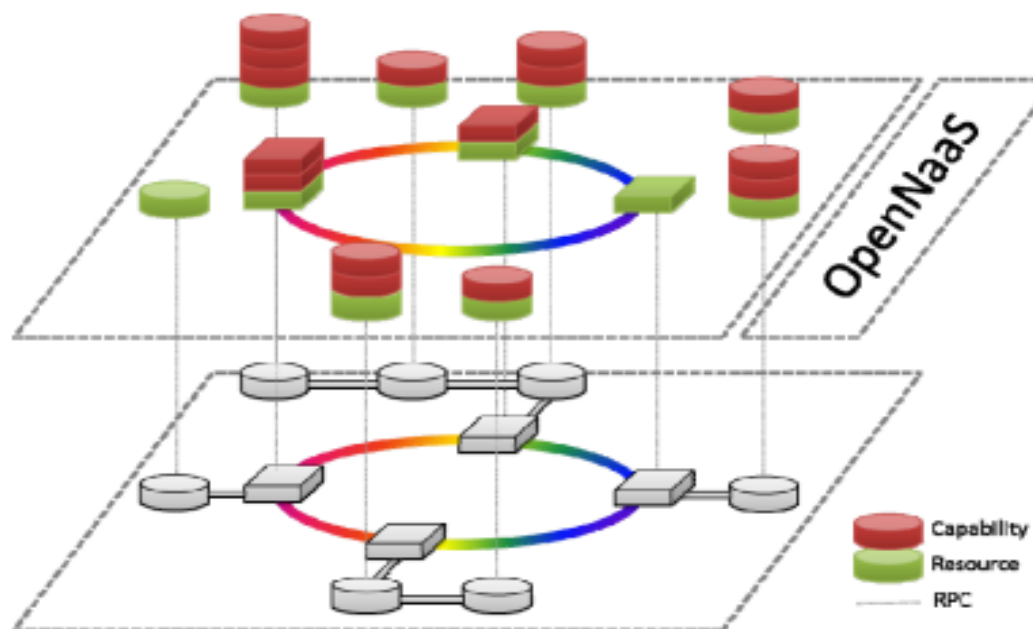

- OpenNaaS allows the creation of a **virtual representation of physical resources** (i.e. network, router, switch, optical device or computing server)
- Virtualization support through **slicing or aggregation**

# OpenDaylight Virtual Tenant Network (VTN)

## Virtual Network Provisioning

- VTN design (Add/Delete/Change)
- VTN model operation (Add/Delete/Change)

## Flow Control over Virtual Network

- Flow filter (Forward, Drop, Redirect or Remarking)

## QoS Control over Virtual Network

- Policing
  - Forward, Drop, Remarking or Drop-precedence for three-color action

## Virtual Network Monitoring

- VTN information collection
  - Traffic statistics
  - Failure events